

Class F3P Radio Control Indoor Aerobatic Model Aircraft

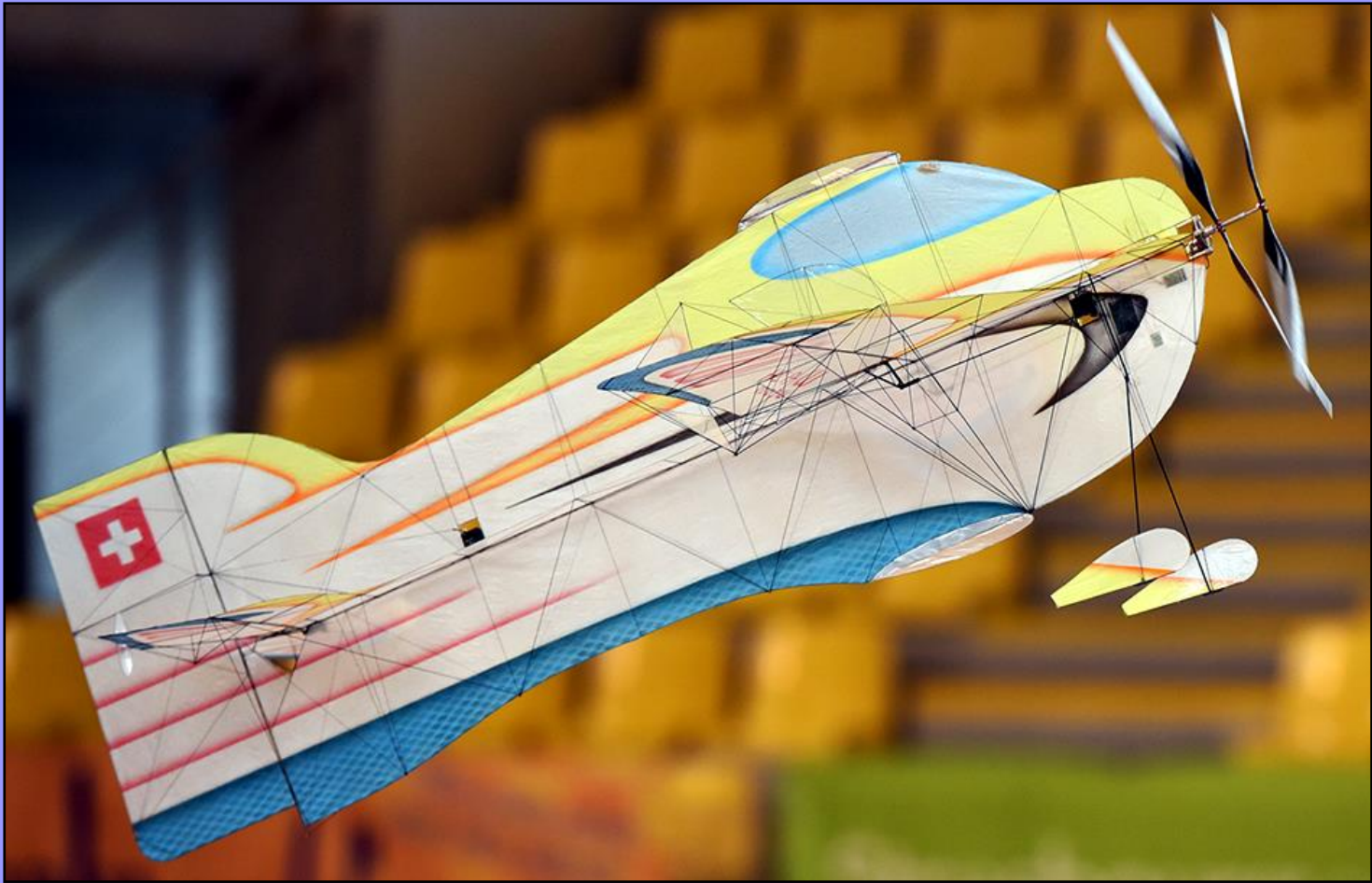

Final Schedule F3P-AF 23 (2022-2023)

FINAL SCHEDULE AF-23 (2022-2023)

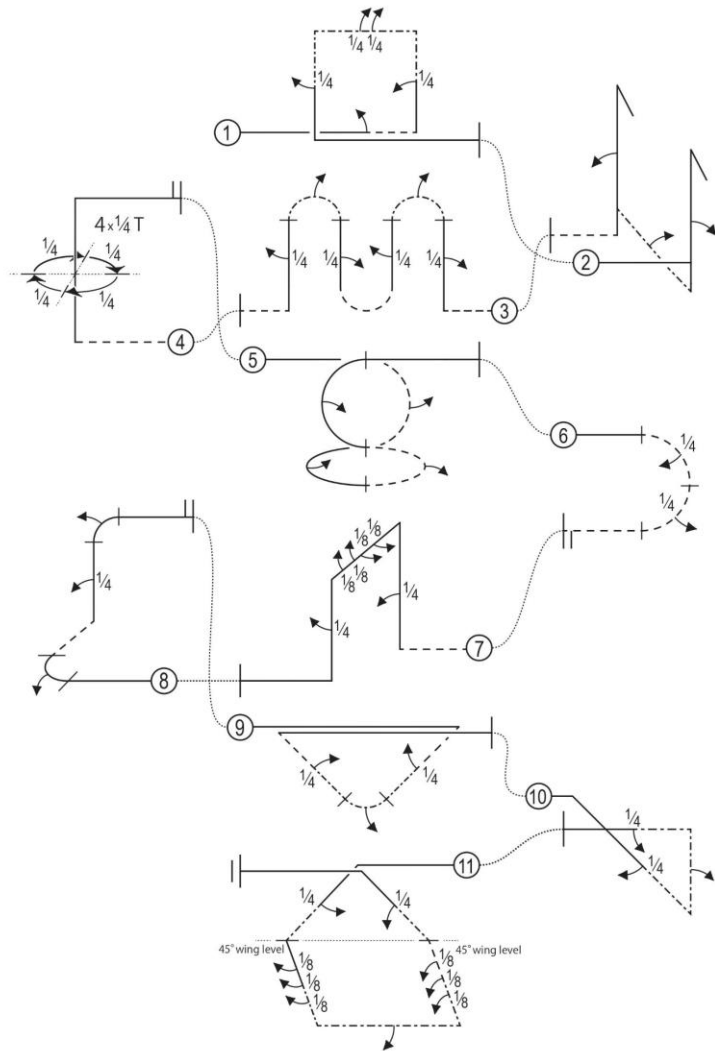

FINAL SCHEDULE AF-23 (2022-2023)

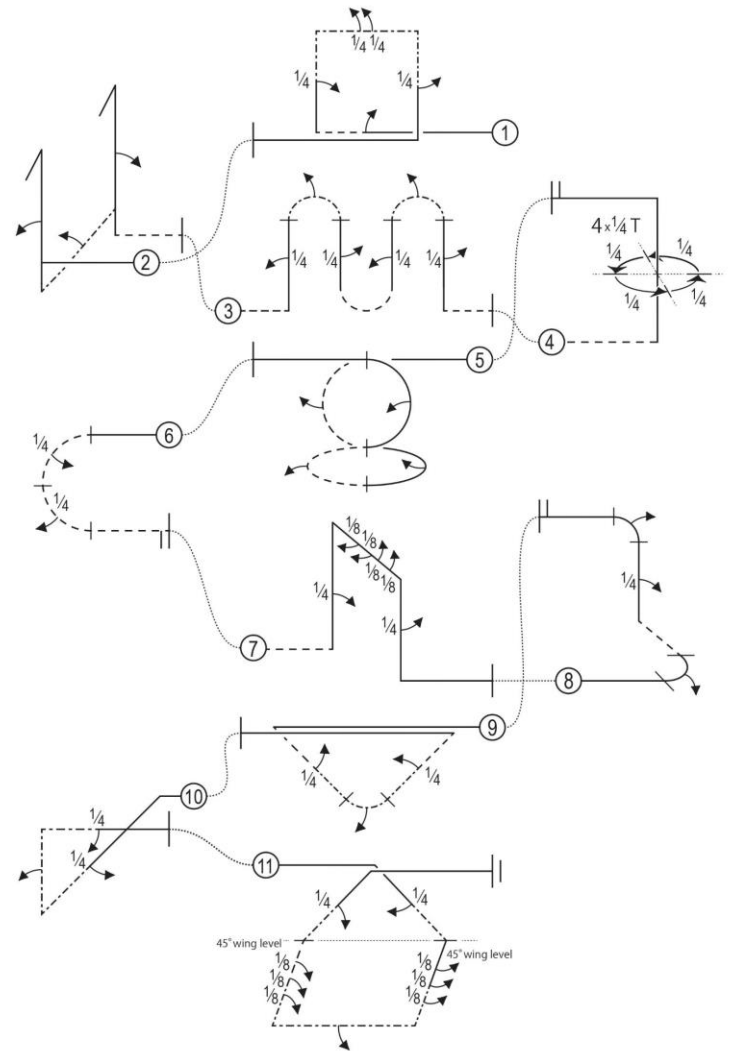

Take-off procedure (not judged, not scored)

Explanations:

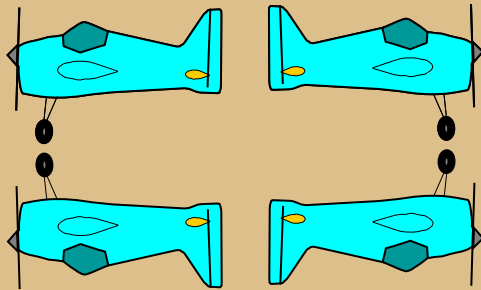

Aircraft upright

Aircraft inverted

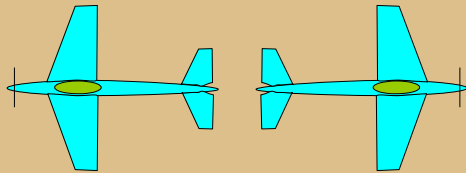

Aircraft in Knife Edge
View from Top

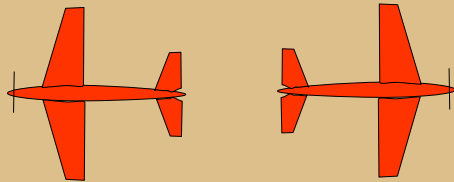

Aircraft in Knife Edge
View from Below



Reference points

Safety line



AF-23.01 Square Loop with half roll, quarter roll, two consecutive quarter rolls, quarter roll

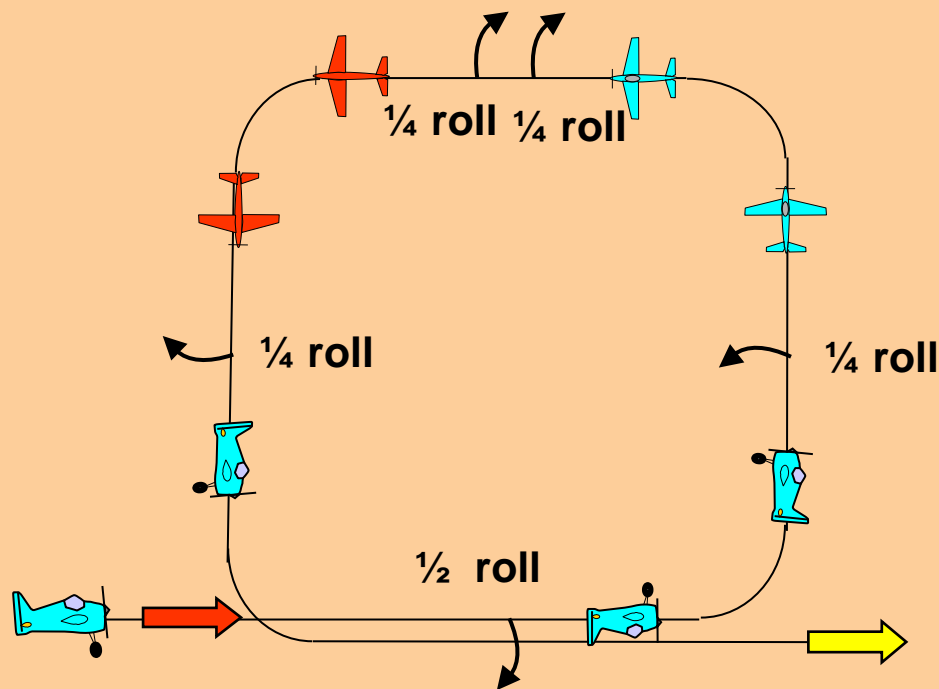

From upright, perform a half roll in the center, push through a quarter loop into a vertical upline, perform a quarter roll, perform a quarter knife-edge loop into knife-edge flight, perform consecutively two consecutive quarter rolls in the center, perform a quarter knife-edge loop into a vertical downline, perform a quarter roll, pull through a quarter loop, exit upright.



AF-23.01 Square Loop with half roll, quarter roll, two consecutive quarter rolls, quarter roll

All part rolls on middle of the lines.

Line between part rolls must be short and of recognizable length.

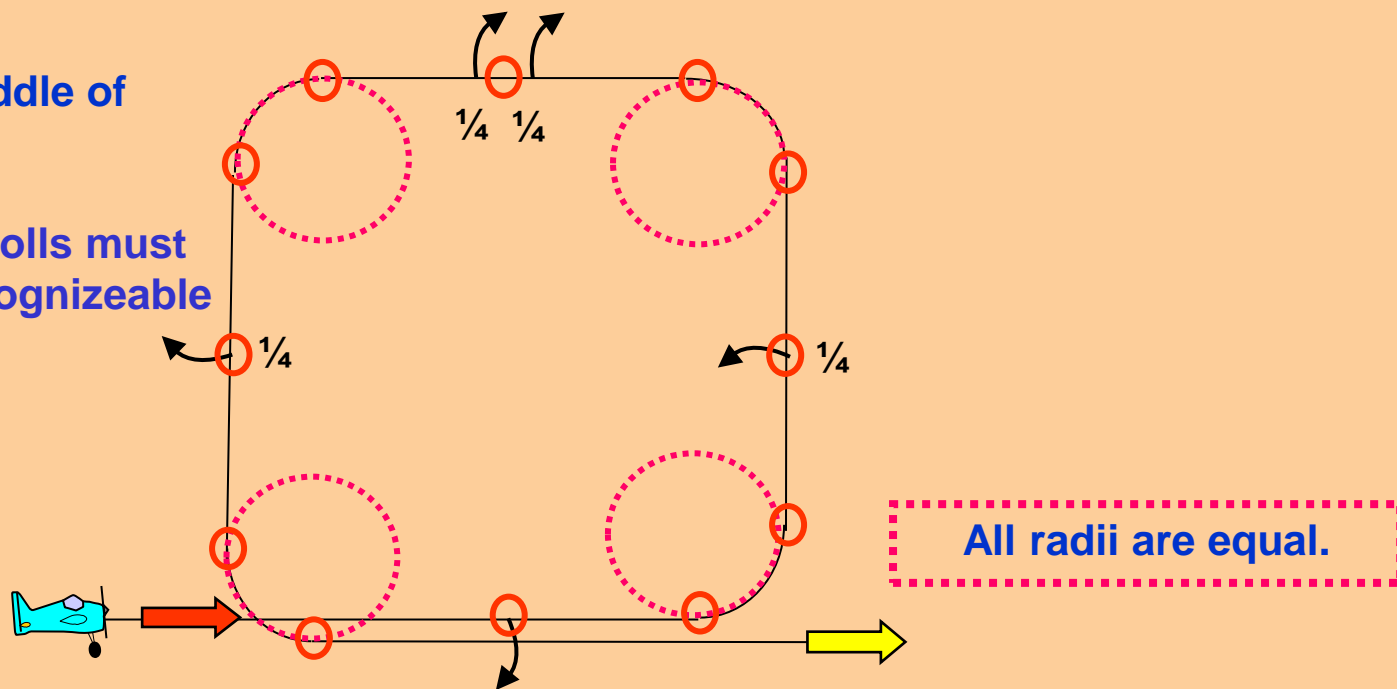

Entry and exit must be at the same altitude.

During the knife edge the wing must be in the vertical plane.



AF-23.02 Double Stall Turn with half roll, half roll, half roll

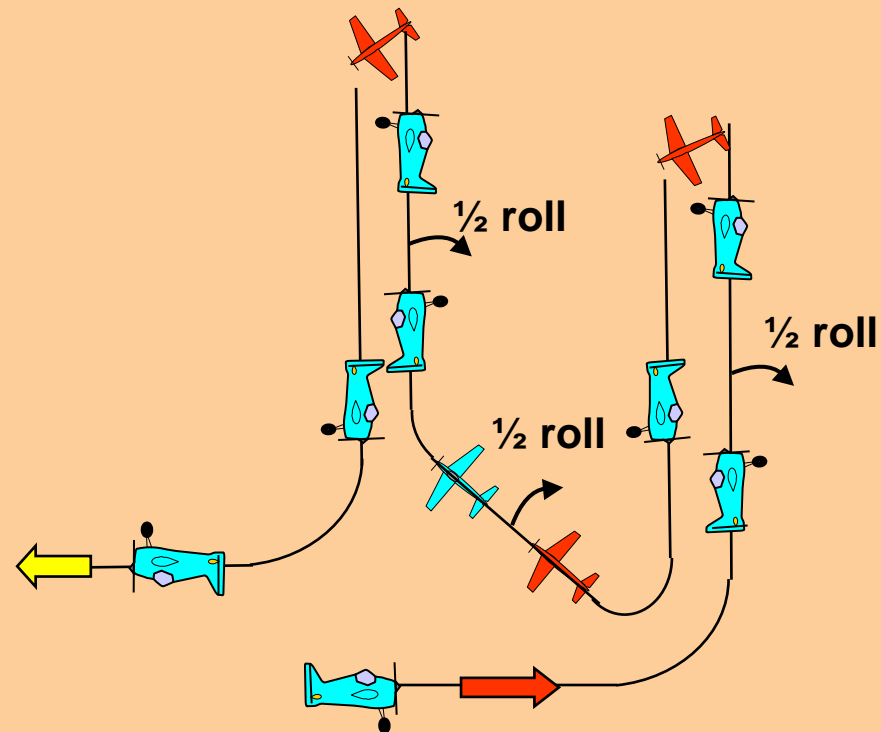

From upright, pull through a quarter loop into a vertical upline, perform a half roll, perform a stall turn into a vertical downline, perform a quarter knife-edge loop into a knife-edge crossbox line, perform a half roll, perform a quarter knife-edge loop into a vertical upline, perform a half roll, perform a stall turn into a vertical downline, push through a quarter loop, exit inverted.



AF-23.02 Double Stall Turn with half roll, half roll, half roll

$\frac{1}{2}$ rolls on middle of the lines.

During the knife edge the wing must be in the vertical plane.

All radii are equal.

Pivot on CG
Two wing spans or more –
zero points!

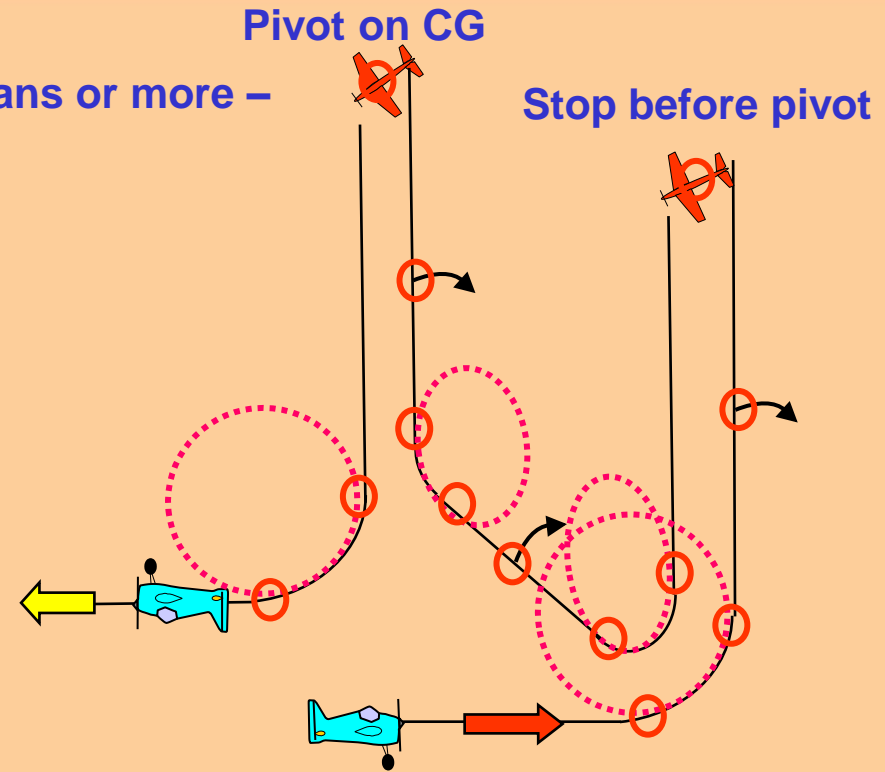

AF-23.03 Double Humpty Bump with quarter roll, half roll integrated, quarter roll, quarter roll, half roll integrated, quarter roll

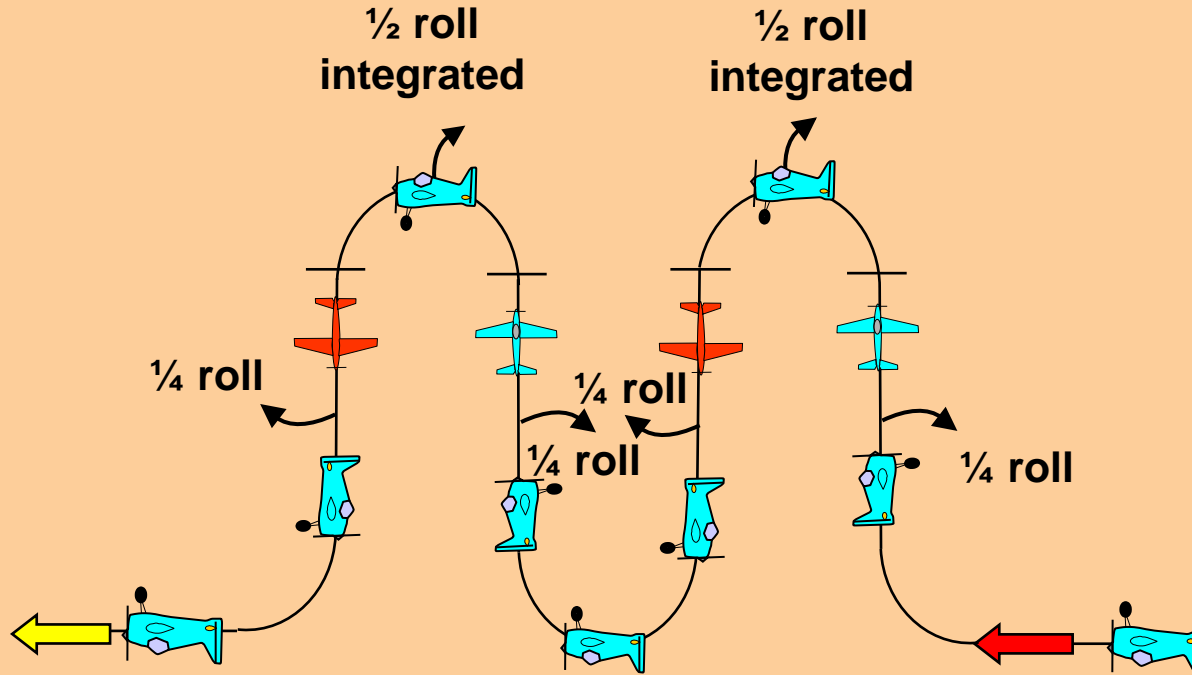

From inverted, before the center push through a quarter loop into a vertical upline, perform a quarter roll, perform a half knife-edge loop (towards the center) with integrated half roll into a vertical downline, perform a quarter roll, push through a half loop in the center into a vertical upline, perform a quarter roll, perform a half knife-edge loop (away from the center) with integrated half roll into a vertical downline, perform a quarter roll, push through a quarter loop, exit inverted.



AF-23.03 Double Humpty Bump with quarter roll, half roll integrated, quarter roll, quarter roll, half roll integrated, quarter roll

The $\frac{1}{2}$ rolls must be integrated on circular flightpath of the $\frac{1}{2}$ loop.

$\frac{1}{4}$ rolls on middle of the lines.

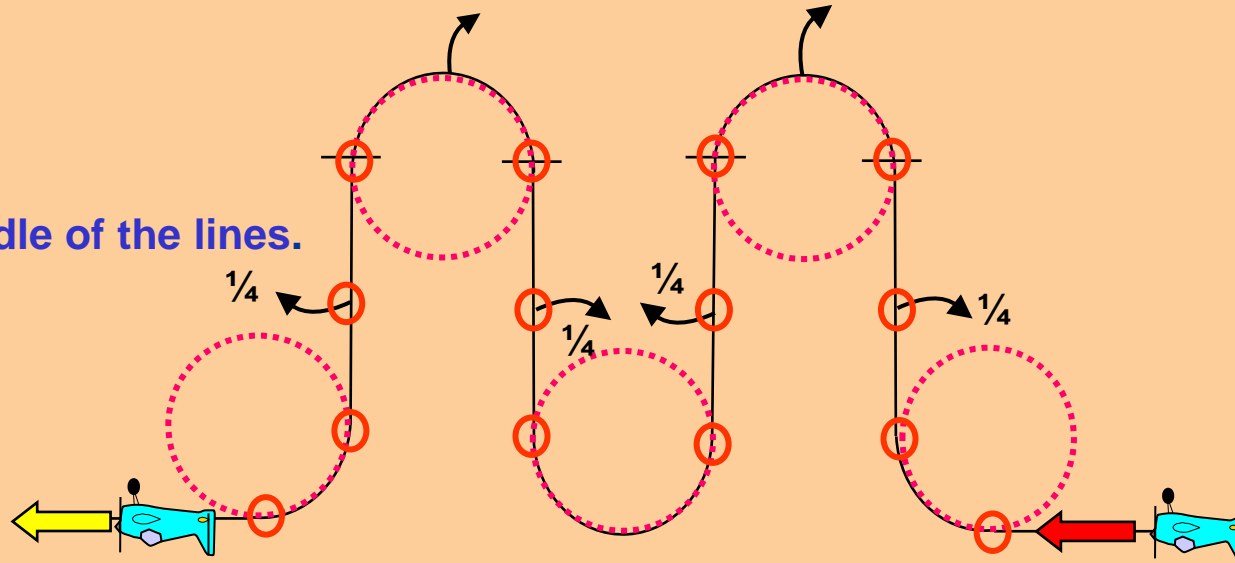

Entry and exit must be at the same altitude.

All radii are equal.



AF-23.04 Half Square Loop with four consecutive one quarter torque rolls

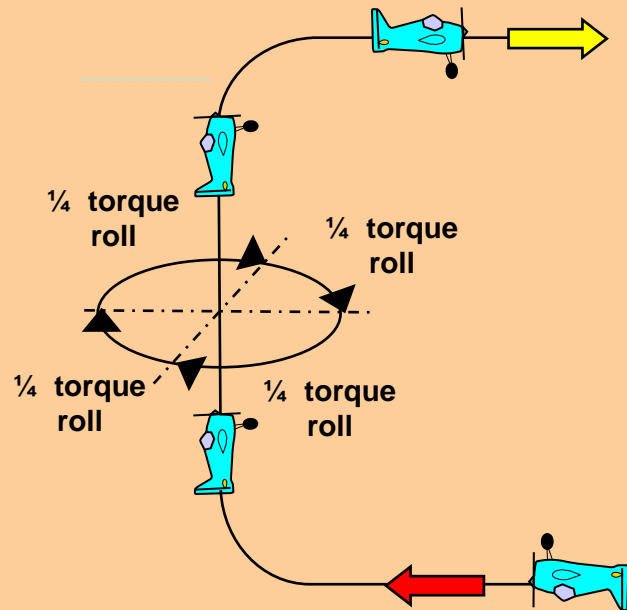

From inverted, push through a quarter loop into a vertical upline, perform consecutively four one quarter torque rolls on same level, push through a quarter loop, exit upright.



AF-23.04 Half Square Loop with four consecutive one quarter torque rolls

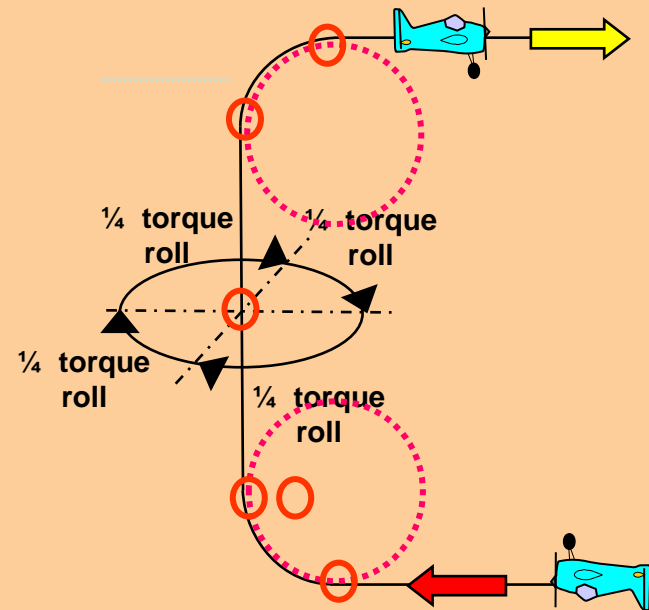

Lines before and after the four $\frac{1}{4}$ torque rolls must be of equal length.

Rolling speed must be constant.

Absence of a hover = **zero**.

All radii are equal.



AF-23.05 Loop Crossbox Circle Combination with half roll integrated, half roll integrated, half roll integrated, half roll integrated

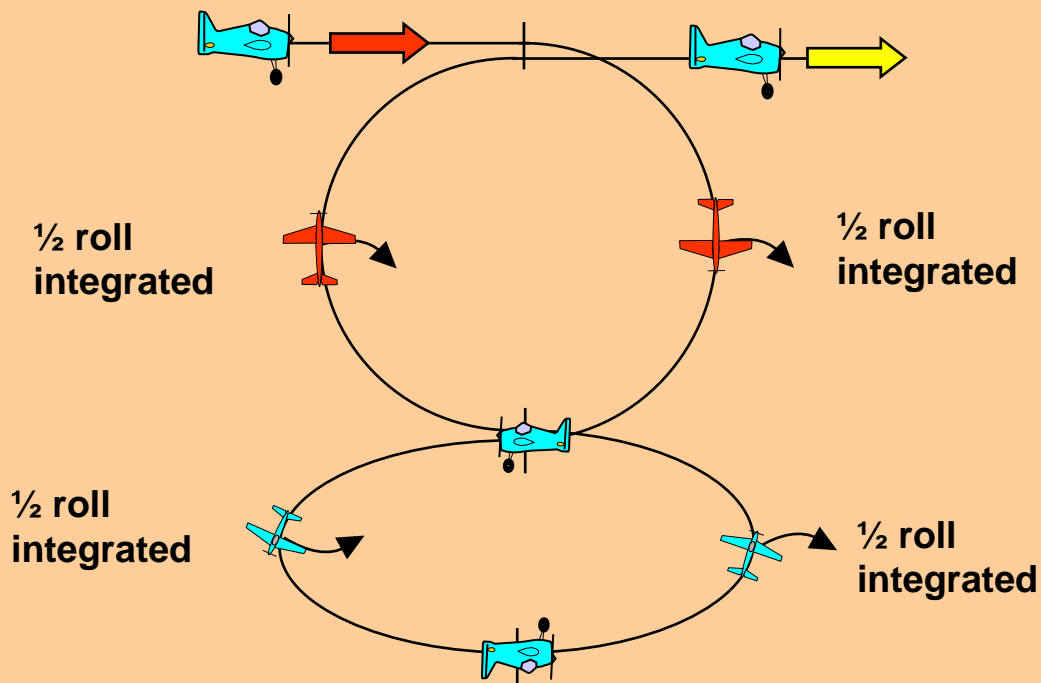

From upright, push through a half loop, while integrating a half roll, perform a crossbox circle with two half rolls in opposite directions integrated, pull through a half loop, while integrating a half roll in opposite direction of the half roll in the first half loop, exit upright.



AF-23.05 Loop Crossbox Circle Combination with half roll integrated, half roll integrated, half roll integrated, half roll integrated

Entry and exit must be at the same altitude.

Loop and circle must be round.

$\frac{1}{2}$ rolls must be integrated on circular flightpath of the loop and the circle.

$\frac{1}{2}$ rolls integrated in the circle must be in opposite direction.

Change of rolling direction must be immediate.

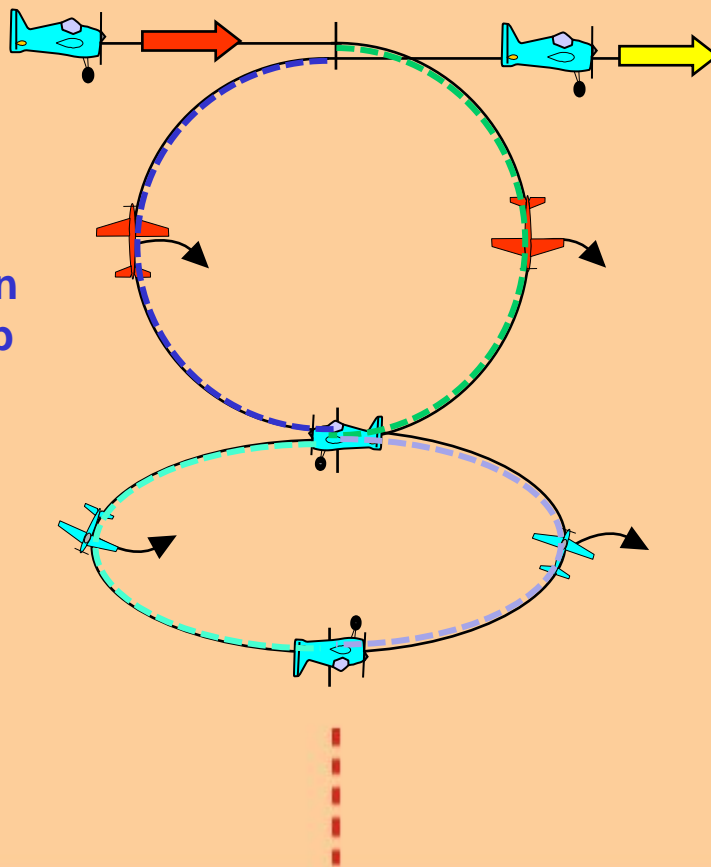

Fourth half roll integrated must be in opposite direction to the first.

Rolling direction:
left, left, right, right
or
right, right, left, left
or
right left, right, left
or
left, right, left, right.

AF-23.06 AF-23.06 Half Loop with two consecutive quarter rolls in opposite directions integrated

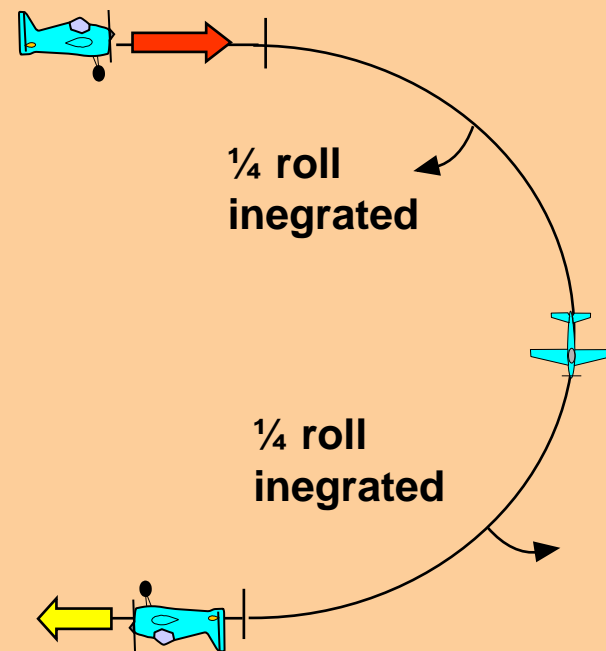

From upright push through a half loop while integrating consecutively two quarter rolls in opposite directions, exit inverted.

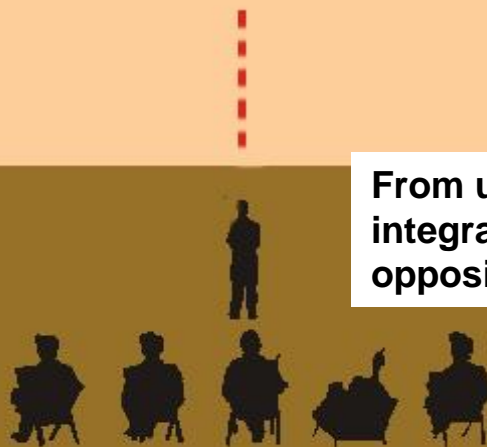

AF-23.06 Half Loop with two consecutive quarter rolls in opposite directions integrated

$\frac{1}{2}$ loop has to be round.

The $\frac{1}{4}$ rolls must be integrated on circular flightpath of the $\frac{1}{2}$ loop.

Roll reversal has to be immediately.

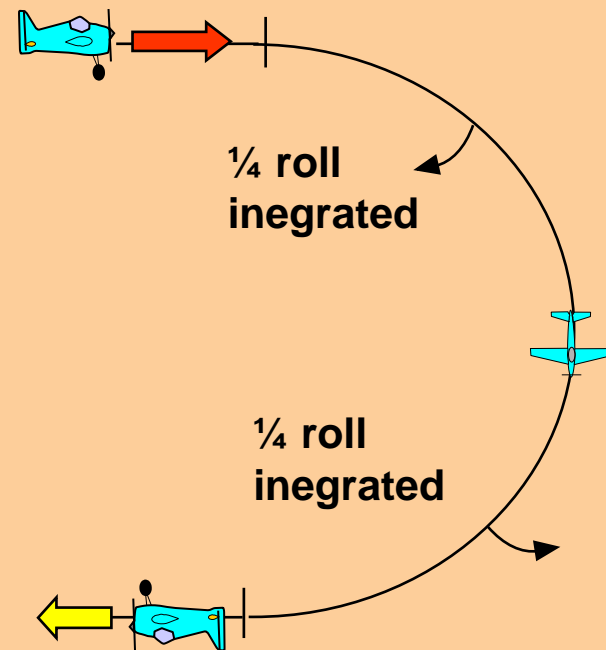

AF-23.07 Crossbox Top Hat with quarter roll, two consecutive one eighth rolls, two consecutive one eighth rolls in opposite direction, quarter roll

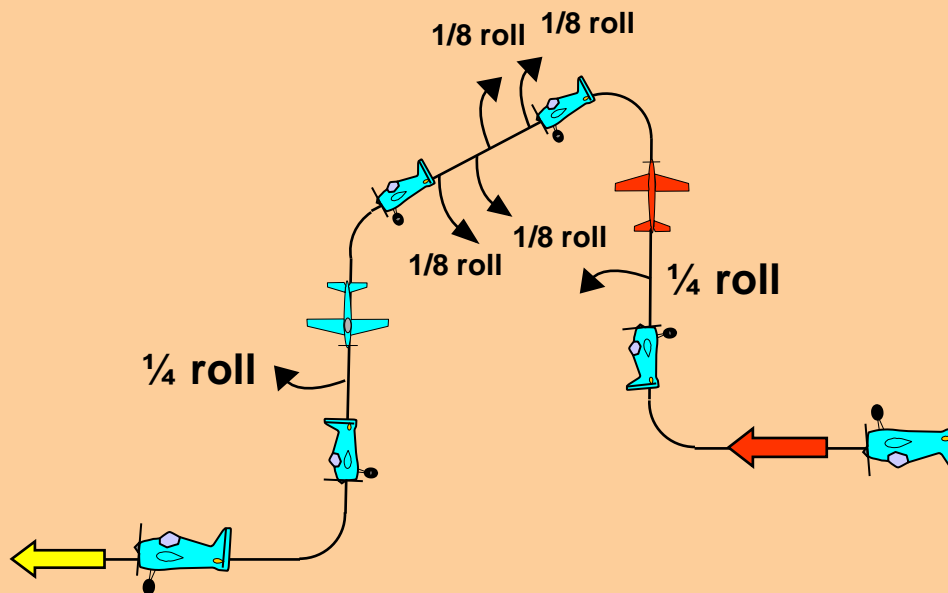

From inverted, push through a quarter loop into a vertical upline, perform a quarter roll, push through a quarter loop into a horizontal crossbox line, perform consecutively two one eighth rolls, followed by two consecutive one eighth rolls in opposite direction, push through a quarter loop into a vertical downline, perform a quarter roll, pull through a quarter loop, exit upright.



AF-23.07 Crossbox Top Hat with quarter roll, two consecutive one eighth rolls, two consecutive one eighth rolls in opposite direction, quarter roll

All part rolls centered on middle of the lines.

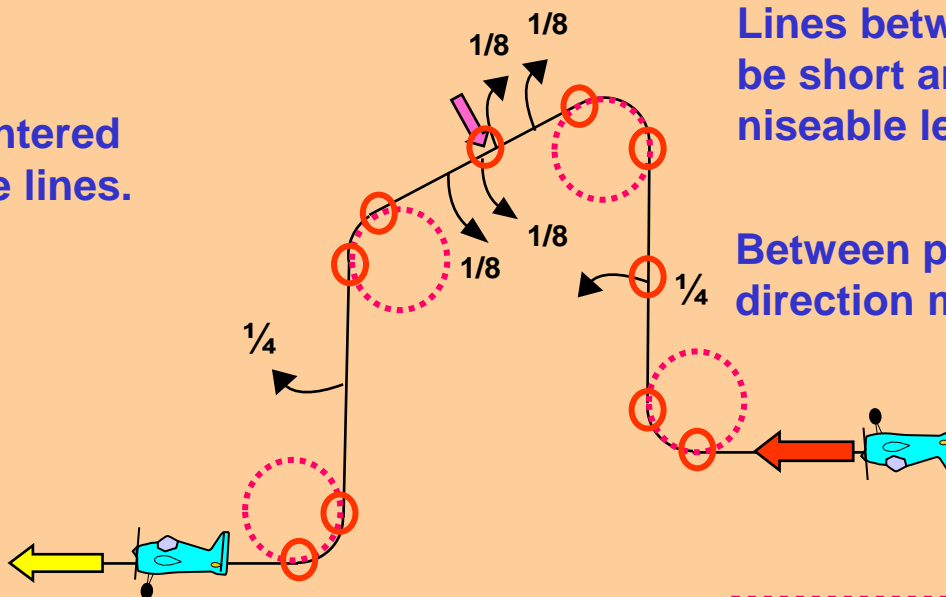

Lines between part rolls must be short and of equal recognisable length.

Between part rolls in opposite direction must be no line.

Entry and exit must be at the same altitude.

All radii are equal.



AF-23.08 Corner Combination with half roll integrated, quarter roll, half roll integrated

$\frac{1}{2}$ roll
inegrated

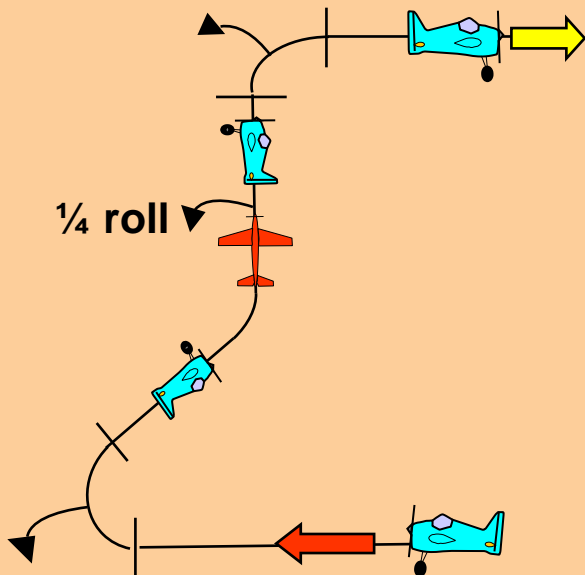

$\frac{1}{2}$ roll
inegrated

From upright, perform a quarter circle into a crossbox line, while integrating a half roll, push through a quarter loop into a vertical upline, perform a quarter roll, pull through a quarter loop while integrating a half roll, exit upright.



AF-23.08 Corner Combination with half roll integrated, quarter roll, half roll integrated

$\frac{1}{2}$ roll
inegrated

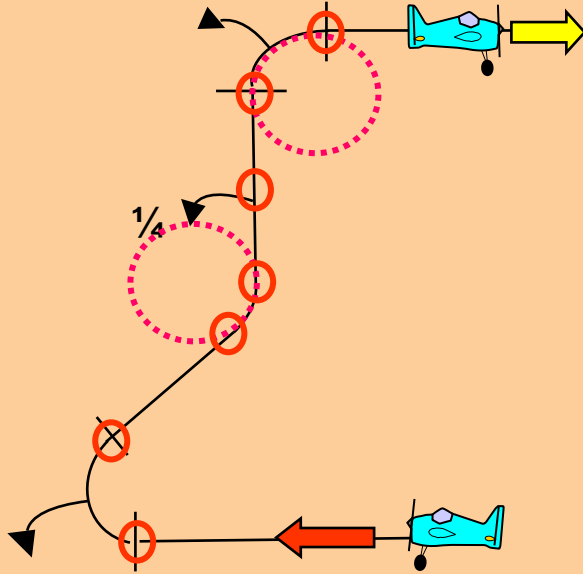

$\frac{1}{2}$ roll
inegrated

$\frac{1}{4}$ roll on middle of the line.

The $\frac{1}{2}$ rolls must be integrated on circular flightpath of the $\frac{1}{4}$ circle and of the $\frac{1}{4}$ loop.

The radii of the part loops are equal.



AF-23.09 Triangle with quarter roll, half roll integrated, quarter roll

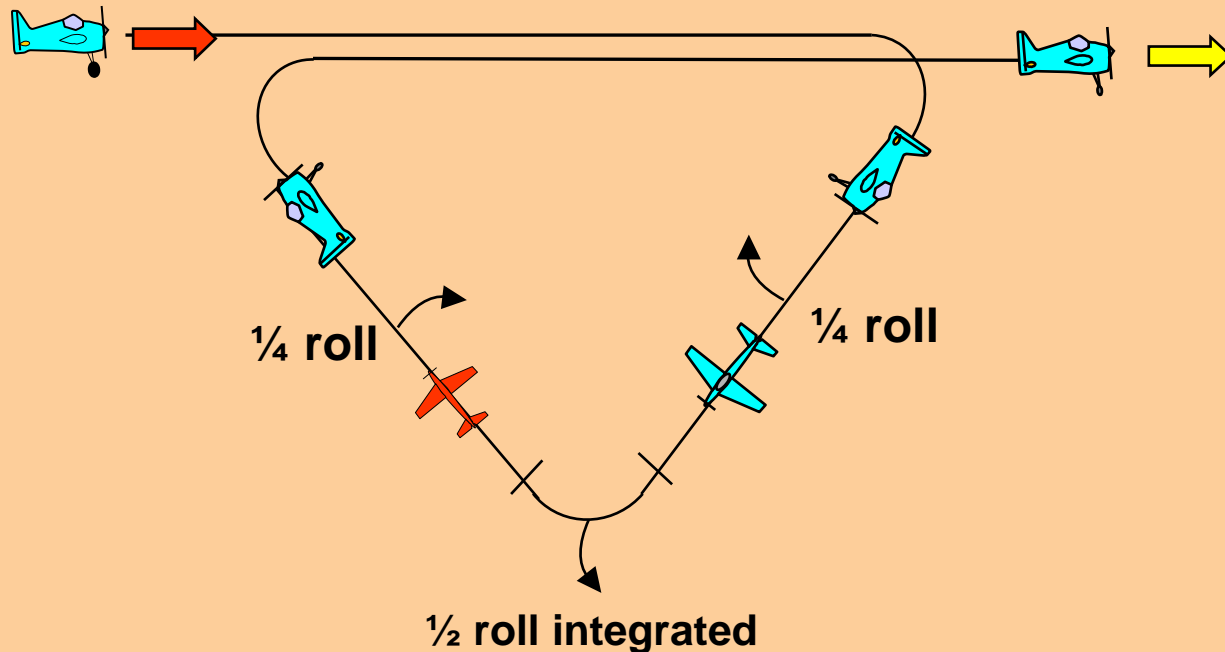

From upright, fly past center, push through a three eighths loop into a forty-five degree downline, perform a quarter roll, perform a quarter knife-edge loop into a forty-five degree upline, while integrating a half roll, perform a quarter roll, push through a three eighths loop, exit upright.



AF-23.09 Triangle with quarter roll, half roll integrated, quarter roll

Entry and exit must be at the same altitude.

During the knife-edge the wing must be in the vertical plane.

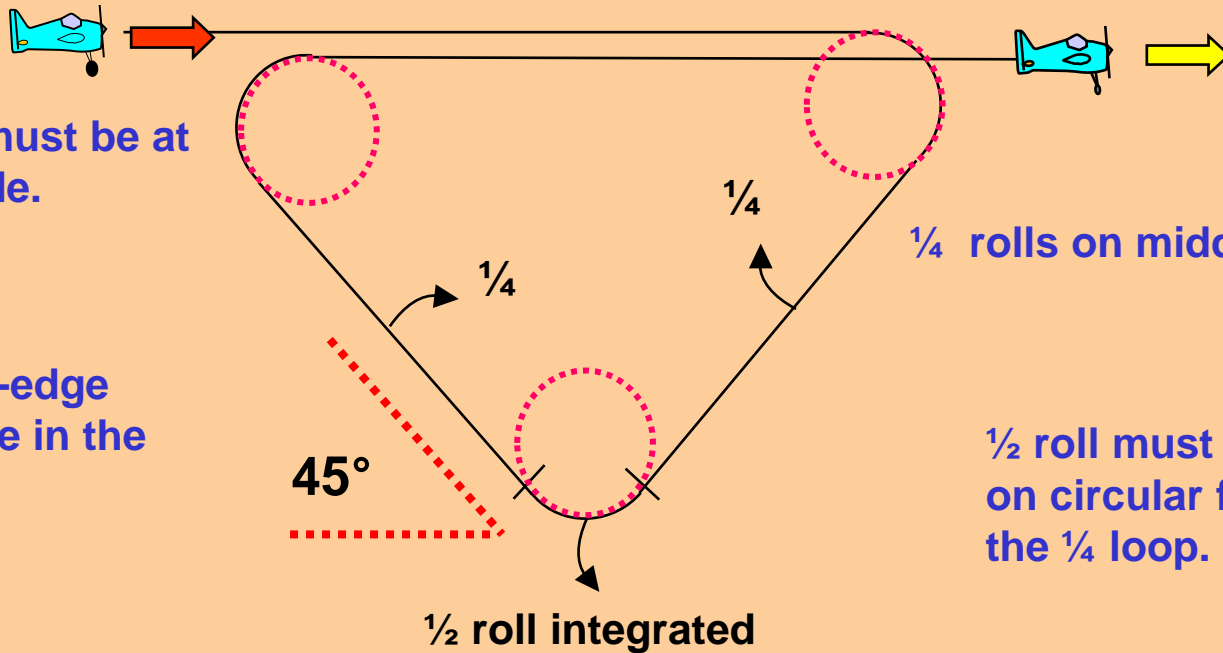

$\frac{1}{4}$ rolls on middle of the line.

$\frac{1}{2}$ roll must be integrated on circular flightpath of the $\frac{1}{4}$ loop.

All radii are equal.



AF-23.10 Reverse Shark Fin from Top with quarter roll, half roll, quarter roll

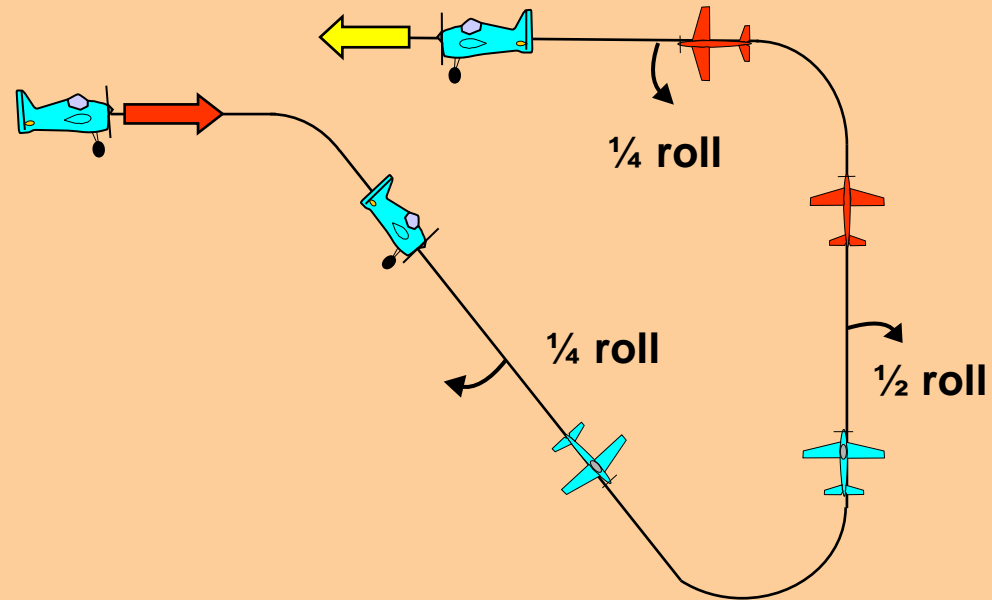

From upright, push through a one eighth loop into a forty-five degree downline, perform a quarter roll, perform a three eighths knife-edge loop into a vertical upline, perform a half roll, perform a quarter knife-edge loop, perform a quarter roll, exit upright.



AF-23.10 Reverse Shark Fin from Top with quarter roll, half roll, quarter roll

Part rolls on middle of the line.

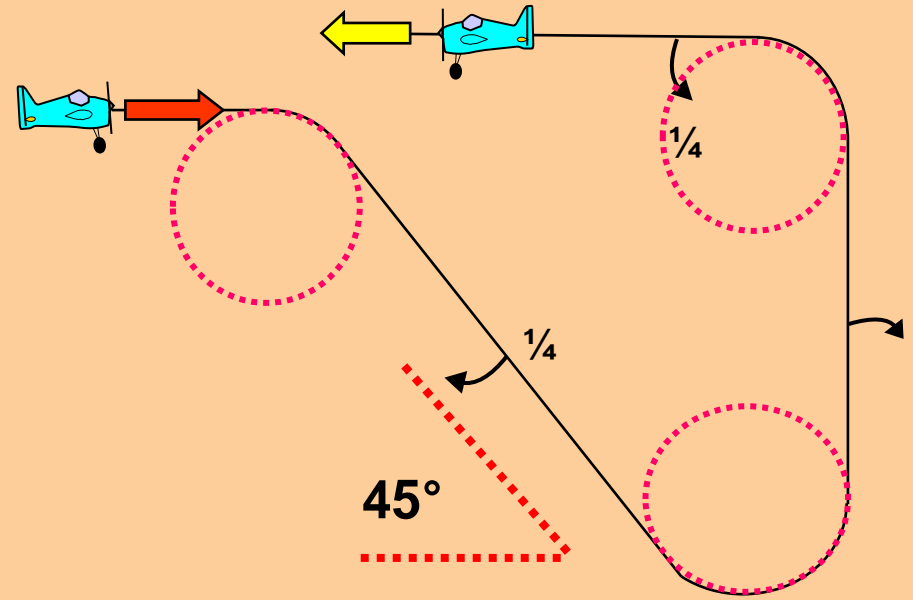

All radii are equal.



AF-23.11 Triangle Crossbox Square Combination with quarter roll, three consecutive one eighth rolls, half roll, three consecutive one eighth rolls, quarter roll

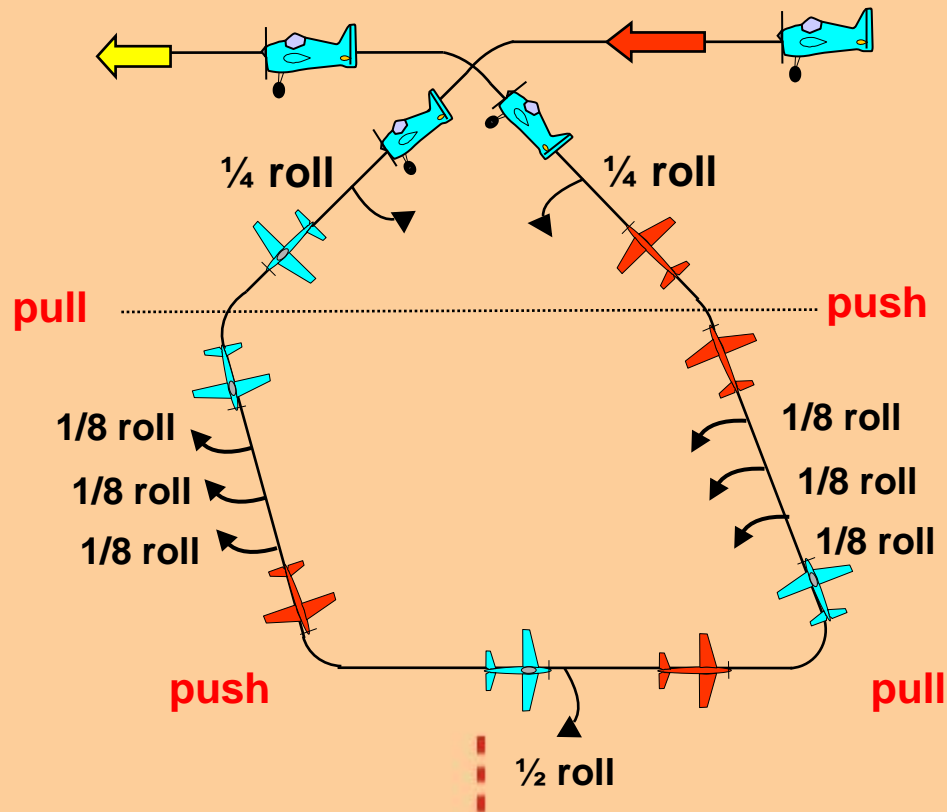

From upright, **push** through a one eighth loop into a forty-five degree downline, perform a quarter roll, **pull** through a quarter knife-edge loop into a crossbox line with forty-five degree wing level, perform consecutively three one eighth rolls into knife-edge flight, **push** through a quarter knife-edge circle, perform a half roll, pull through a quarter knife-edge circle into a knife-edge crossbox line, perform consecutively three one eighth rolls into forty five degree wing level flight, **push** through a quarter knife-edge loop into a forty-five degree upline, perform a quarter roll, push through a one eighth loop, exit upright.

AF-23.11 Triangle Crossbox Square Combination with quarter roll, three consecutive one eighth rolls, half roll, three consecutive one eighth rolls, quarter roll

Option

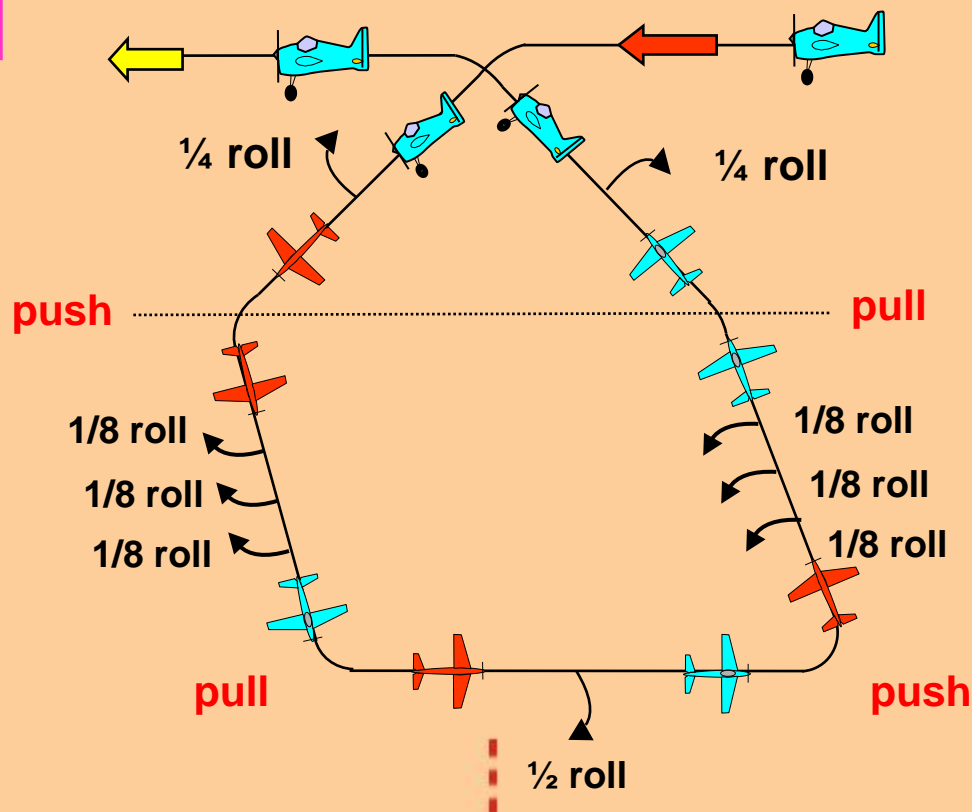

From upright, push through a one eighth loop into a forty-five degree downline, perform a quarter roll, **push** through a quarter knife-edge loop into a crossbox line with forty-five degree wing level, perform consecutively three one eighth rolls into knife-edge flight, **pull** through a quarter knife-edge circle, perform a half roll, **push** through a quarter knife-edge circle into a knife-edge crossbox line, perform consecutively three one eighth rolls into forty five degree wing level flight, **pull** through a quarter knife-edge loop into a forty-five degree upline, perform a quarter roll, push through a one eighth loop, exit upright.

Note: Exit starts in the center.

AF-23.11 Triangle Crossbox Square Combination with quarter roll, three consecutive one eighth rolls, half roll, three consecutive one eighth rolls, quarter roll

Entry and exit must be at the same altitude.

1/8 rolls centered on middle of the line.

During the knife-edge the wing must be in the vertical plane.

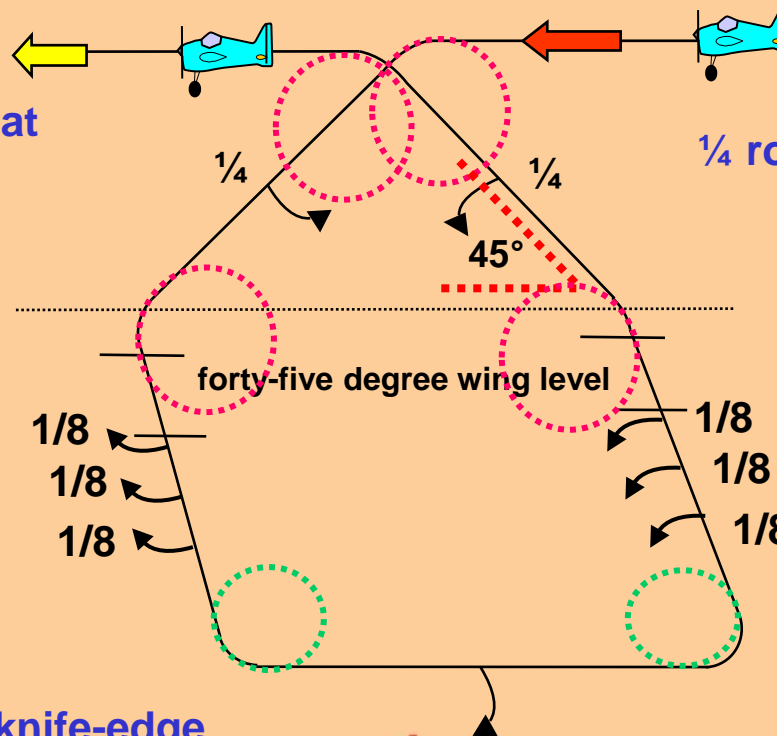

$1/4$ rolls on middle of the line.

Radii of part loops are equal.

Radii of knife-edge part circles are equal.



Landing sequence
(not judged, not scored)

Forget **WHO** is flying
(friend, rival, countryman, flier from other nation)

Forget **WHAT** is flying

LOOK ONLY AT LINES DESCRIBED
(and the precision, smoothness, positioning, and size)

Bob Skinner

Safety line



© Peter Uhlig, October 2021